

HOAC[®] Turntables.
The modular way of turning.

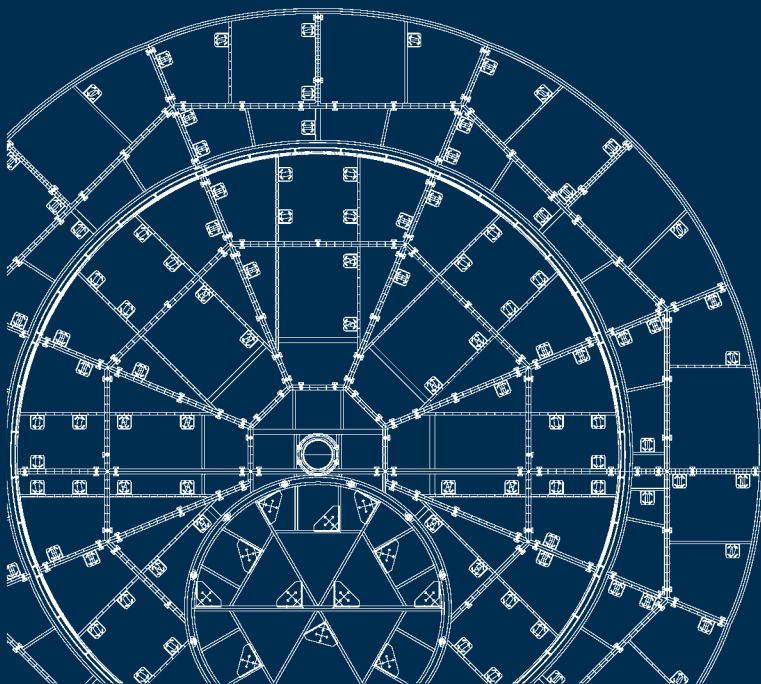

- TRUSS SYSTEMS
- PLATFORMS & STAGING
- TURNTABLES**
- MOBILE STAGE WAGONS
- GRANDSTANDS
- STAGE DESIGN
- FLY BAR SYSTEMS
- TRACK SYSTEMS
- MOBILE BALLET FLOOR
- MOBILE ACOUSTIC SHELLS



HOAC® Turntables. Move your world.

HOAC® Turntables are fast, safe and easy in setup and modular in size. Various options of motors and controls leave no gap between your dream and the reality. Up to 30 m diameter, a building height starting at 16,6 cm our turntables are designed for 500Kg/sqm static load and 250Kg/sqm dynamic load.

Speed goes up to 0,8m/sec or more, but also long time slow movements are possible.

We offer different drive technologies, due to your conditions and demands.



Turntable Frames

HOAC® Turntable frame

- > Easy connection with our Link Blocks
- > 100mm castor wheel are fixed build in
- > Swivel- or turtle castor optional for moving the turntable back stage.
- > Modular design allows easy extension or reduction of the diameter

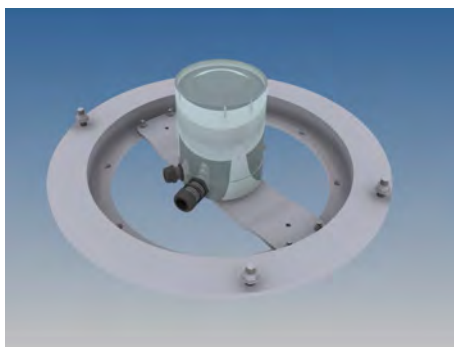

Slip Rings

HOAC® Slip Rings will bring not only power to the motors but also power for additional lighting or other motors. DMX, Audio or even fiber glas can be a option. Data signals for positioning and/or customer requirement can be added.

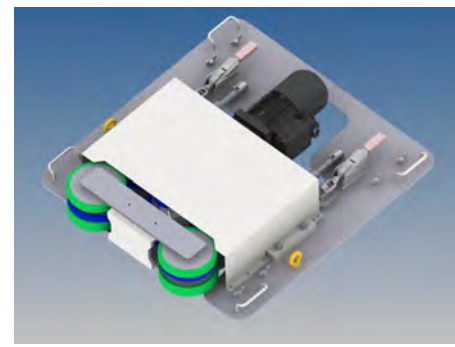

Motors

HOAC® Motors are available in different options. Using asynchron or servo motors we can offer you friction drives from inside the turn table but also from outside the turn table. Beside our standard, we design speed, power and building height towards your needs.

HOAC® SCHWEISSTECHNIK GMBH
 PFERDSWEIDE 39C | 47441 MOERS | GERMANY
 PHONE +49.2841.90828-0 | FAX -70 |
 INFO@HOAC.COM | WWW.HOAC.COM

ASIA AND PACIFIC | HONG KONG | WWW.HOAC.HK
 CHINA | BEIJING | WWW.HOAC.CN
 BENELUX | AK ENSCHEDE | WWW.EOSLINK.NET
 NORTHERN EUROPE | STEGE | WWW.HOAC.COM

HOAC®
 Stage Technology

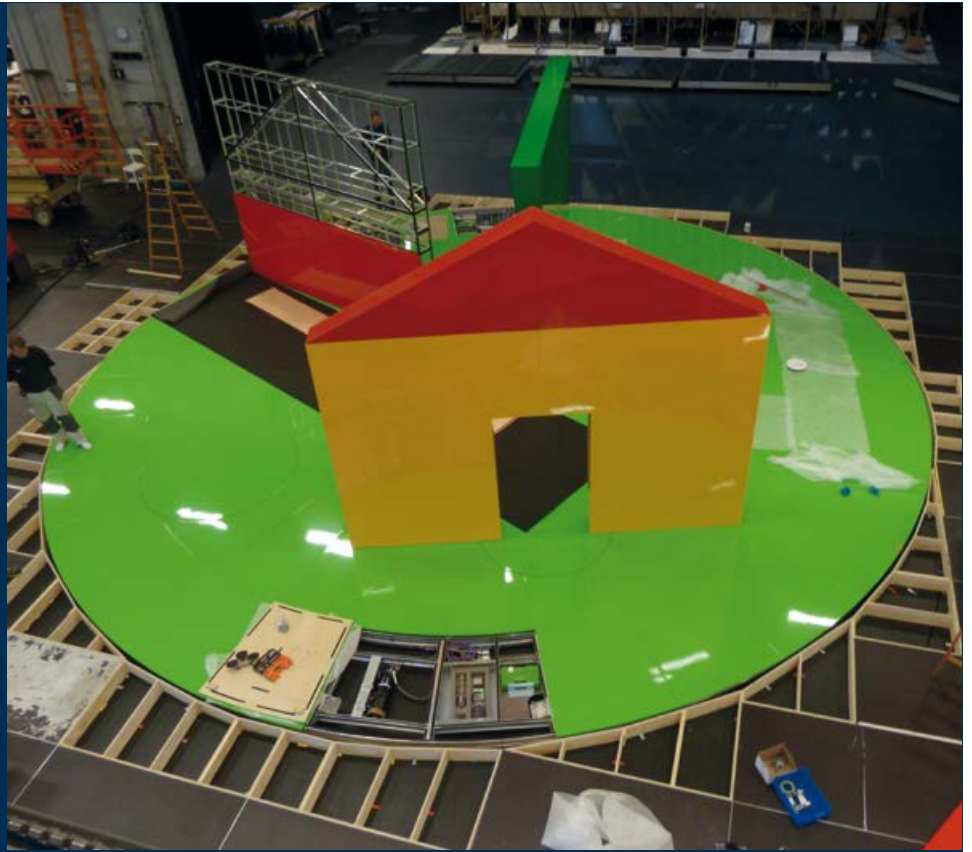

HOAC[®] Turntables go GreenPack
Mobile energy for maximum flexibility.

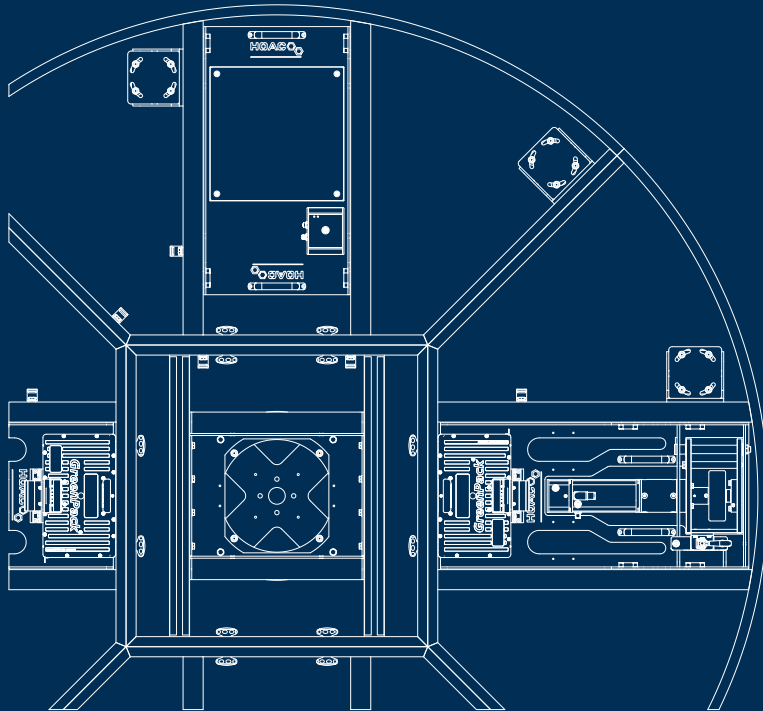

TRUSS SYSTEMS
PLATFORMS & STAGING
TURNTABLES
MOBILE STAGE WAGONS
GRANDSTANDS
STAGE DESIGN
FLY BAR SYSTEMS
TRACK SYSTEMS
MOBILE BALLET FLOOR
MOBILE ACOUSTIC SHELLS



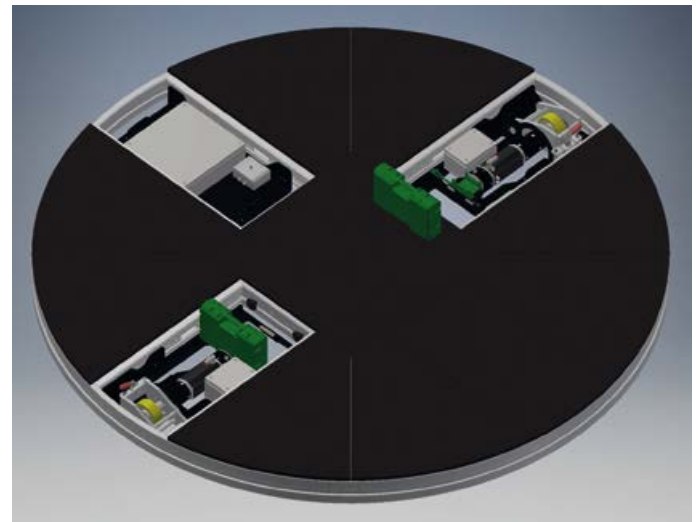
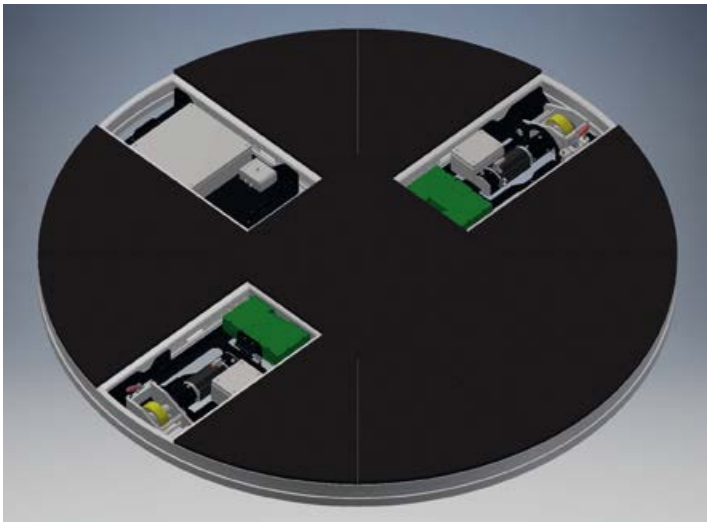

GreenPack stands for an intelligent system with safe power supply, easy transportation and mobile use of regenerative energy.



- ✓ easy handling
- ✓ robust
- ✓ standarsized
- ✓ cluster ready
- ✓ certified
(VW 38.3 & EN 62133)



A standard-Akkumulator for different applications
48V / 1400Wh (29Ah) / 8,8kg / CAN-Bus



GreenPack accumulator

With a weight of only 9 kg and dimensions of 375 mm x 95 mm x 325 mm the accumulator makes the application very easy.



Charger case

We provide charger and discharger cases for convinient and easy handling.



HOAC Frames

HOAC® frames are characterized by the tight link block connection between the frames. The modular design allows easy extension or reduction. The overall standard height of turntables and stage wagons is 200 mm including the decks.



Control panel

HOAC® control technology in connection with our partner Füllung & Partner is developed for cable free accumulator application. 1 - 8 motor units can be controlled and up to 10 different positions can be programmed. The system enables turns and moves in any direction.

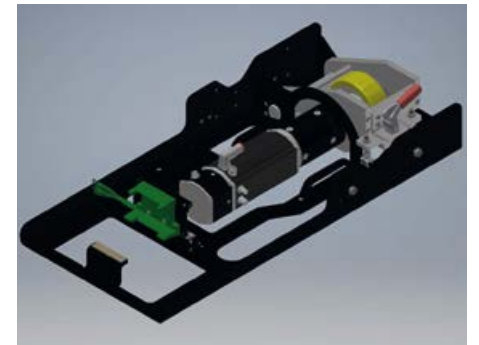

Motors

HOAC® uses Dunkermotor 4Q Servo motors with a nominal voltage of 48 V to assure a smooth friction drive. The capacity of the motor is 1 kW and the nominal speed is 0,8 m / sec.

HOAC® SCHWEISSTECHNIK GMBH
 PFERDSWEIDE 39C | 47441 MOERS | GERMANY
 PHONE +49.2841.90828-0 | FAX -70 |
 INFO@HOAC.COM | WWW.HOAC.COM

ASIA AND PACIFIC | HONG KONG | WWW.HOAC.HK
 CHINA | BEIJING | WWW.HOAC.CN
 BENELUX | AK ENSCHEDE | WWW.EOSLINK.NET
 NORTHERN EUROPE | STEGE | WWW.HOAC.COM

